

VILLAGE OF CHATHAM, ILLINOIS

ORDINANCE NO. 00 - 05

AN ORDINANCE AMMENDING ORDINANCE 99-53
(AN ORDINANCE APPROVING A BID FOR PLUMMER BLVD BIKE TRAIL)

ADOPTED BY THE PRESIDENT AND BOARD OF TRUSTEES OF THE VILLAGE OF
CHATHAM, ILLINOIS THIS 25TH DAY OF JANUARY, 2000

Published in pamphlet form by the authority of the President and
Board of Trustees of the Village of Chatham, Sangamon County,
Illinois, this 25TH day of January, 2000.

ORDINANCE NO. 00-05

AN ORDINANCE AMENDING ORINANCE 99-53
(AN ORDINANCE APPROVING A BID FOR PLUMMER BLVD BIKE TRAIL)

WHEREAS, on the 9th of November, 1999 President and Board of Trustees passed and approved Ordinance 99-53, approving a bid from Sangamo Construction for \$134,518.22 for construction of an underpass to accommodate the Plummer Blvd Bike Trail; and

WHEREAS, engineering review of the project has increased the required material and scope of the project; and

WHEREAS, on January 17th, 2000 the Public Works Committee met to review the attached correspondence from Sangamo Construction increasing the project by \$55,852.30 and is recommending the increased amount be accepted.

NOW, THEREFORE, BE IT ORDAINED BY THE PRESIDENT AND BOARD OF TRUSTEES OF THE VILLAGE OF CHATHAM, ILLINOIS, AS FOLLOWS:

SECTION 1: That the bid from Sangamo Construction be increased from \$134,518.22 to \$190,370.52 is hereby approved.

SECTION 2: This Ordinance is effective upon its passage and approval.

PASSED THIS 25th DAY OF JANUARY, 2000

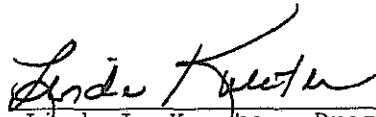
Linda L. Koester, President
Village of Chatham

ATTEST:

Robert A. Krueger, Village Clerk

AYES: 6
NAYS: 0
ABSENT: 0

PASSED: _____
APPROVED: _____

ORDINANCE CERTIFICATE

STATE OF ILLINOIS)
) SS.
COUNTY OF SANGAMON)

I, the undersigned, do hereby certify that I am the duly qualified and acting Village Clerk of the Village of Chatham, Sangamon County, Illinois.

I do further certify that the Ordinance attached hereto is a full, true, and exact copy of Ordinance No. 00-___, adopted by the President and Board of Trustees of said Village on the 25th day of January, 2000, said Ordinance being entitled:

AN ORDINANCE AMMENDING ORDINANCE 99-53
(AN ORDINANCE APPROVING A BID FOR PLUMMER BLVD BIKE TRAIL

I do further certify that prior to the making of this certificate, the said Ordinance was spread at length upon the permanent records of said Village, where it now appears and remains.

IN WITNESS WHEREOF, I have hereunto set my hand and affixed the official seal of said Village this 25th day of January, 2000.

Robert A. Krueger, Village Clerk

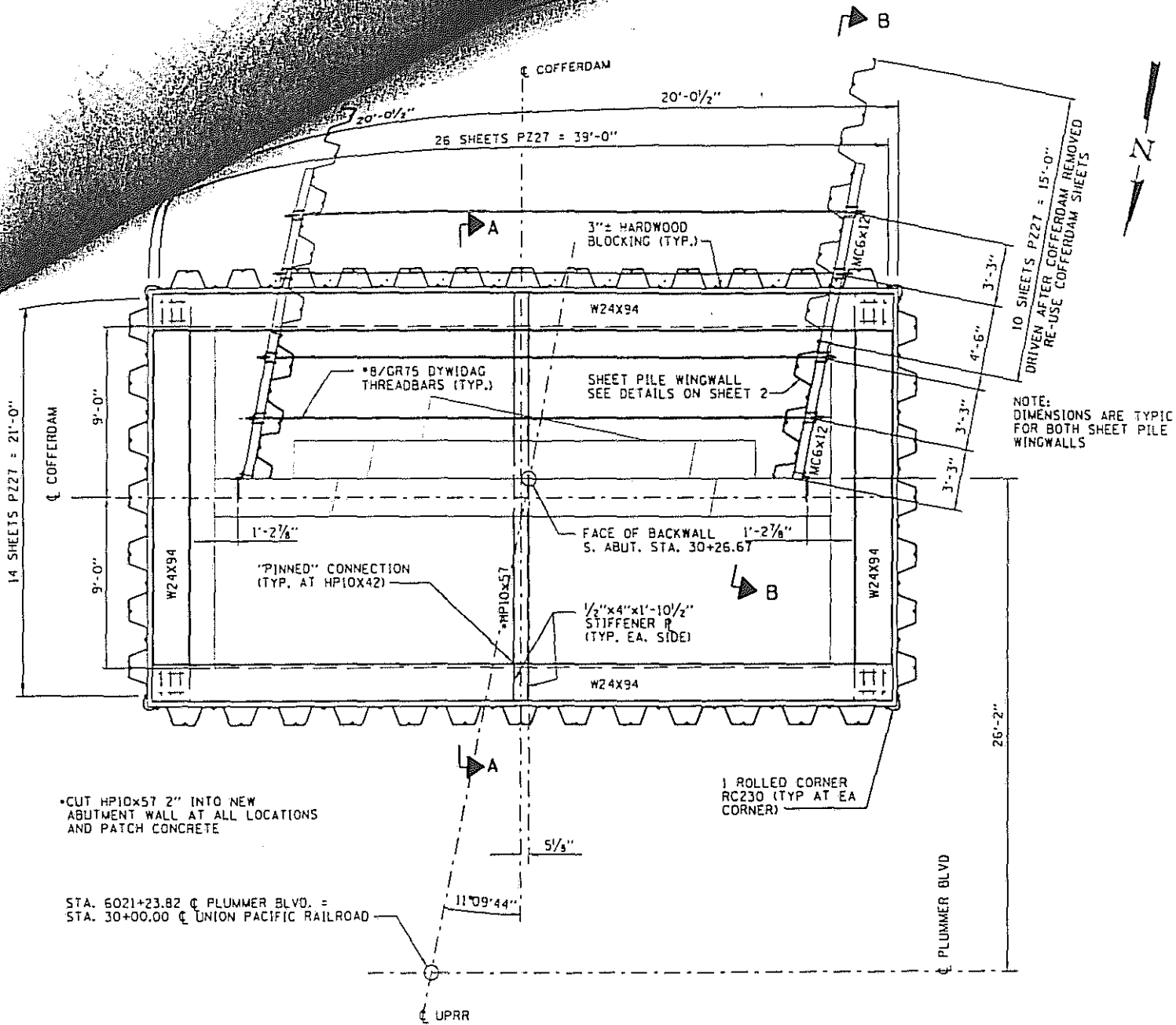

PLAN

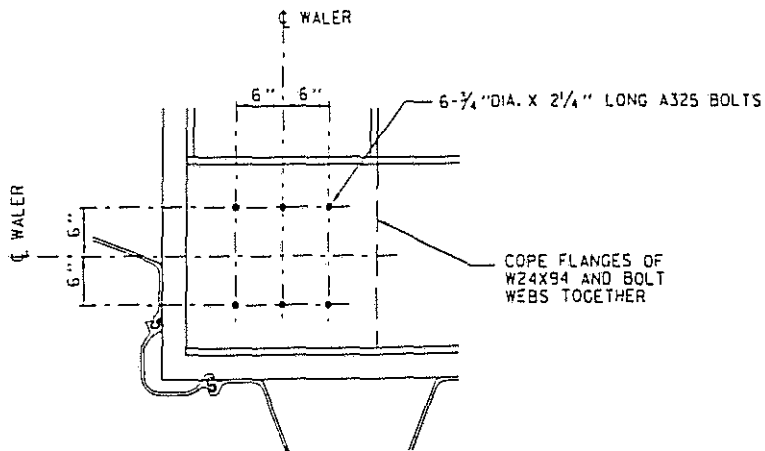

TYPICAL BOLTED CONNECTION AT WALERS

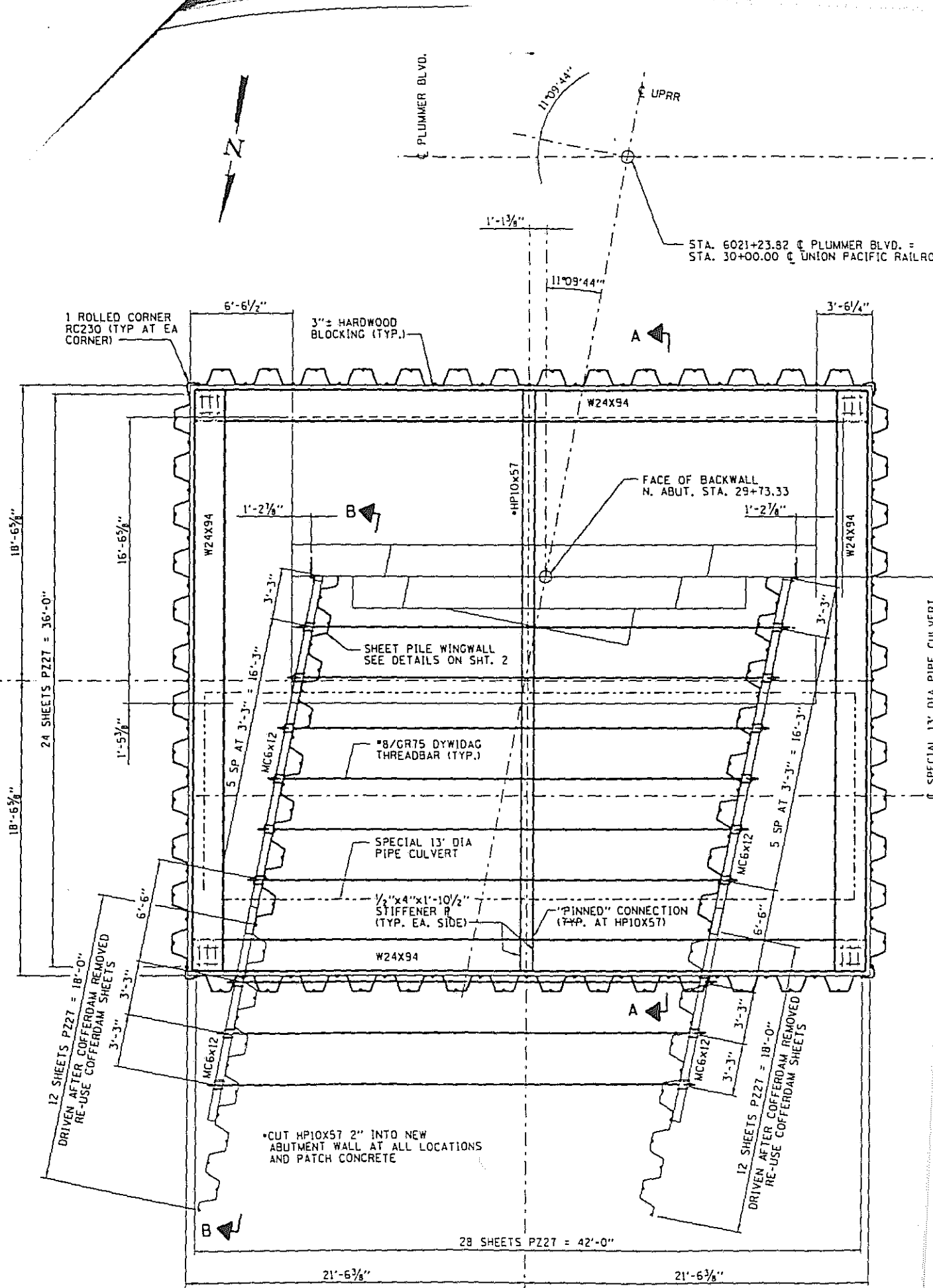

STA. 6021+23.82 @ PLUMMER BLVD. =
STA. 30+00.00 @ UNION PACIFIC RAILROAD

☉ COFFERDAM

☉ SPECIAL 13' DIA PIPE CULVERT

28 SHEETS PZ27 = 42'-0"

12 SHEETS PZ27 = 18'-0"
DRIVEN AFTER COFFERDAM REMOVED
RE-USE COFFERDAM SHEETS

12 SHEETS PZ27 = 18'-0"
DRIVEN AFTER COFFERDAM REMOVED
RE-USE COFFERDAM SHEETS

• CUT HP10X57 2" INTO NEW
ABUTMENT WALL AT ALL LOCATIONS
AND PATCH CONCRETE

PLAN



ADDITIONAL COSTS REVISED COFFERDAMS

ADDITIONAL QUANTITIES & COSTS:

	QTY	UNIT MS.	UNIT \$	EXTENSION
COFFERDAM WALL	1400	SF	\$ 22.41	\$ 31,374.00
COFFERDAM EXC.	397	CY	\$ 15.50	\$ 6,153.50
WING SHEETING	881	SF	\$ 20.80	\$ 18,324.80

TOTAL ADDITIONAL COSTS REVISED COFFERDAMS: **\$ 55,852.30**

COST ANALYSIS ORIGINAL COFFERDAMS:

	QTY	UNIT MS.	UNIT \$	EXTENSION
COFFERDAMS - 2 EA	3600	SF	\$ 18.11	\$ 65,196.00
COFFERDAM EXC.	889	CY	\$ 15.50	\$ 13,779.50
SHEETPILE WINGS	690	SF	\$ 20.80	\$ 14,352.00

\$ 93,327.50